

NOTES:

- IF YOU CAN, PLEASE WRITE YOUR NAME AND PHONE NUMBER ON THE PIECE YOU'RE MAKING.
- IF YOU HAD TO MAKE 8 PIECES SHOWN ON THIS DRAWING, HOW MUCH MATERIAL WOULD YOU NEED? (WRITE YOUR ANSWER ON THE WORKPIECE).

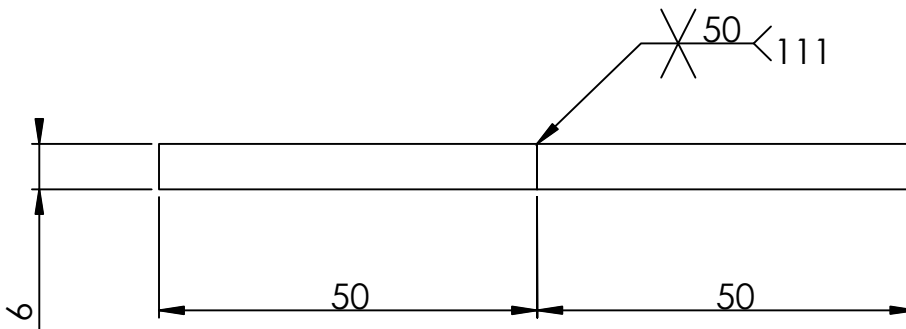

- 1) CUT FROM 40x6 FLAT BAR
- 2) GRIND ONE SIDE FLAT

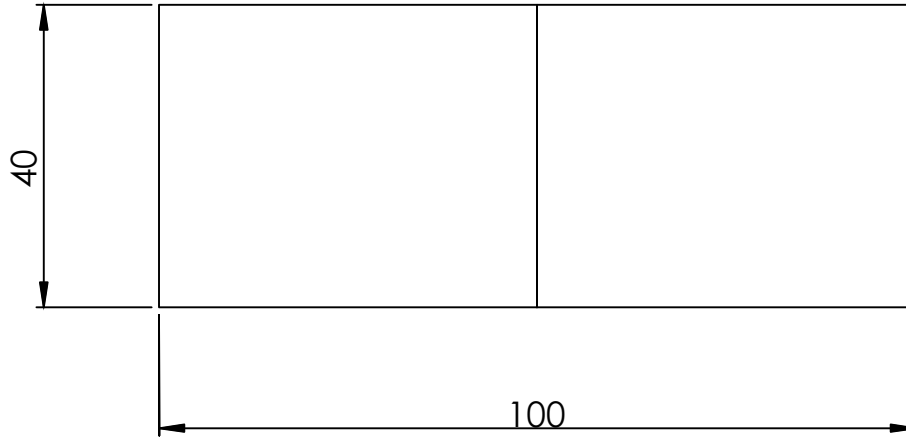

weldingmen

THIS DRAWING IS PROPERTY OF WELDINGMEN

APPROVALS	DATE	FINISH/PAINT	RAW
DESIGNED Martin H.	04/03/2022	MATERIAL	MILD STEEL 40x6 FLAT BAR
DRAWN Tomas L.	04/03/2022	PROJECT NAME <b>MMA WELDING TEST</b>	
CHECKED Andrea R.	04/03/2022		
REV.	D	DESCRIPTION <b>WELD 2 FLAT BARS</b>	
SCALE	1/4	FORMAT	A4
DATE	04/03/2022	PAGE	1/1